



Operating Instructions  
in compliance with  
Pressure Equipment Directive 2014/68/EU  
and  
Pressure Equipment (Safety) Regulation 2016,  
UK Statutory Instrument 2016 No. 1105

Series880-1 Shut-off Regulating Valve



Please read these operating instructions carefully to ensure a safe operation and keep the same for further use.

© 2021 Armaturenwerk Altenburg GmbH | Am Weißen Berg 30 | 04600 Altenburg, Germany





## Table of content

Safety.....	4
Authorized personnel.....	4
Residual hazards.....	4
Symbols used for safety information.....	4
General safety information.....	5
Other information.....	5
Description of valve.....	6
Types.....	6
Operating principle.....	7
Product description.....	7
Identification.....	8
Technical parameters.....	8
Design features.....	9
Transport and Storage.....	9
Mounting.....	10
Principles.....	10
Mounting preparation.....	11
Connecting the pipe.....	11
Assembling valve components.....	12
Commissioning.....	12
Principles.....	12
Steps of commissioning.....	13
Operation, Maintenance and Repair.....	14
Principles.....	14
Repairs.....	14
Dismantling and Disposal.....	15
Principles.....	15
Appendix: Regulating/opening characteristics.....	15

## **Safety**

The Series880-1 Regulating valve cast, hereinafter referred to as valve, is designed for use in refrigeration/air conditioning systems, hereinafter referred to as systems. It may only be put into service if installed in the system unchanged in accordance with these instructions and in its entirety is in compliance with the statutory provisions.

The valve incorporates state-of-the-art technology and has been built according to the applicable regulations. Great value has been set upon the user's safety.

These operating instructions are integral part of the contract and shall be kept throughout the entire life of the valve.

### **Authorized personnel**

Only trained and instructed personnel shall be allowed to do any work on the valve and system. As regards the qualification and expertise of the personnel the applicable rules and guidelines shall apply.





### **Residual hazards**

Unavoidable residual dangers may emanate from the valve. Every person working on this device shall therefore carefully read these instructions!

To be observed are for example:

- the generally accepted safety regulations,
- EC directives,
- Norms (e.g. EN 378) and all national provisions.





### **Symbols used for safety information**

	<b>DANGER!</b> Instructions on preventing imminent serious dangers to persons. Imminent most serious injuries or death as a possible consequence. Any non-observance may lead to an immediate failure of the valve.
	<b>WARNING!</b> Instructions on preventing potential serious danger to persons. Avoidable serious to very serious injuries or death a possible consequence. Any non-observance may cause the valve to fail.
	<b>CAUTION!</b> Instructions on preventing a minor danger to persons. Minor, reversible injuries cannot be excluded. Any non-observance may lead to a medium-term failure of the valve.
	<b>ATTENTION!</b> Instructions on preventing potential damage to equipment. Minor, reversible injuries cannot be excluded. Any non-observance may lead to a medium-term failure of the valve.

## General safety information

These operating instructions are based on the safety requirements of EN 378-2 and EN 12284.

Instructions to prevent hazards in all cycles of service life:

	<b>DANGER!</b> Risk of bursting if operated beyond the technical parameters. Most serious injuries and immediate system failure possible. Observe the technical parameters.
	<b>WARNING!</b> Damage due to improper handling. Serious injuries and system failure possible. Never use valves as transport, lifting or lashing points.
	<b>WARNING!</b> Any non-observance of the instructions may cause the valve to fail. Avoidable serious to very serious injuries or death possible. Installation, operation and maintenance by authorized personnel only.
	<b>WARNING!</b> Risk of service fluid to be released. Depending on the kind of service fluid serious to very serious injuries or death possible as a consequence. Wear personal protective equipment (e.g. respirators, gloves).
	<b>CAUTION!</b> Very cold or very hot surface temperatures possible. Frostbites/burns possible. Wear personal protective equipment (e.g. respirators, gloves).

## Other information

The information contained herein represents to the best of our belief our knowledge at the time when these instructions were prepared. It shall serve as code of practice to ensure a safe handling of the valve in transport, storage, installation, commissioning, maintenance and dismantling/disposal. A final decision as to whether the valve suits the purpose is to be taken by the user. This information shall not be deemed a warranty of quality.

Any modification of the valve and operation under other than the prescribed parameters shall not be allowed and will result in the loss of the conformity declaration and all liability claims.

## Description of valve

### Types

Valve for pipe installation in angular form with protective spindle cap.

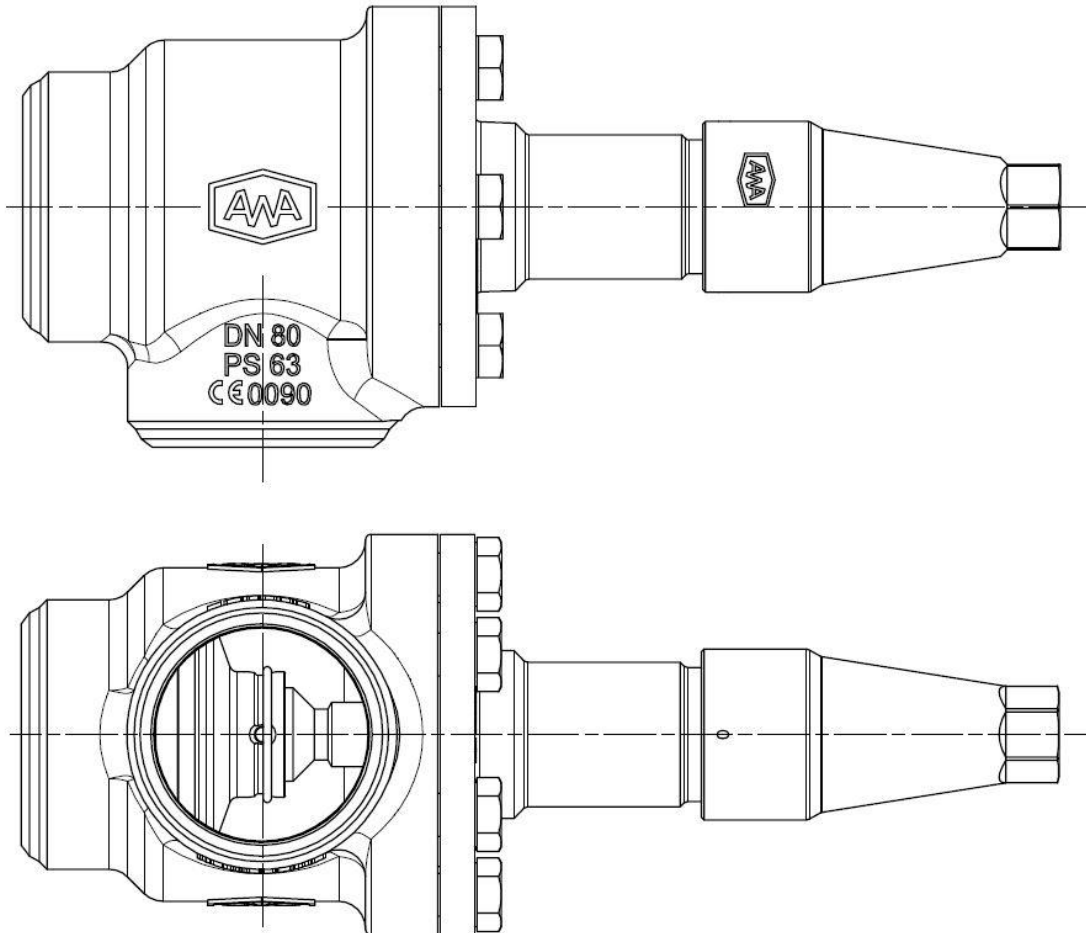

The valves come with two butt weld connections.

Installation dimensions can be gathered from the AWA product catalogue and technical documents respectively. The connecting options are explained in more detail in “Design features”.

## Operating principle

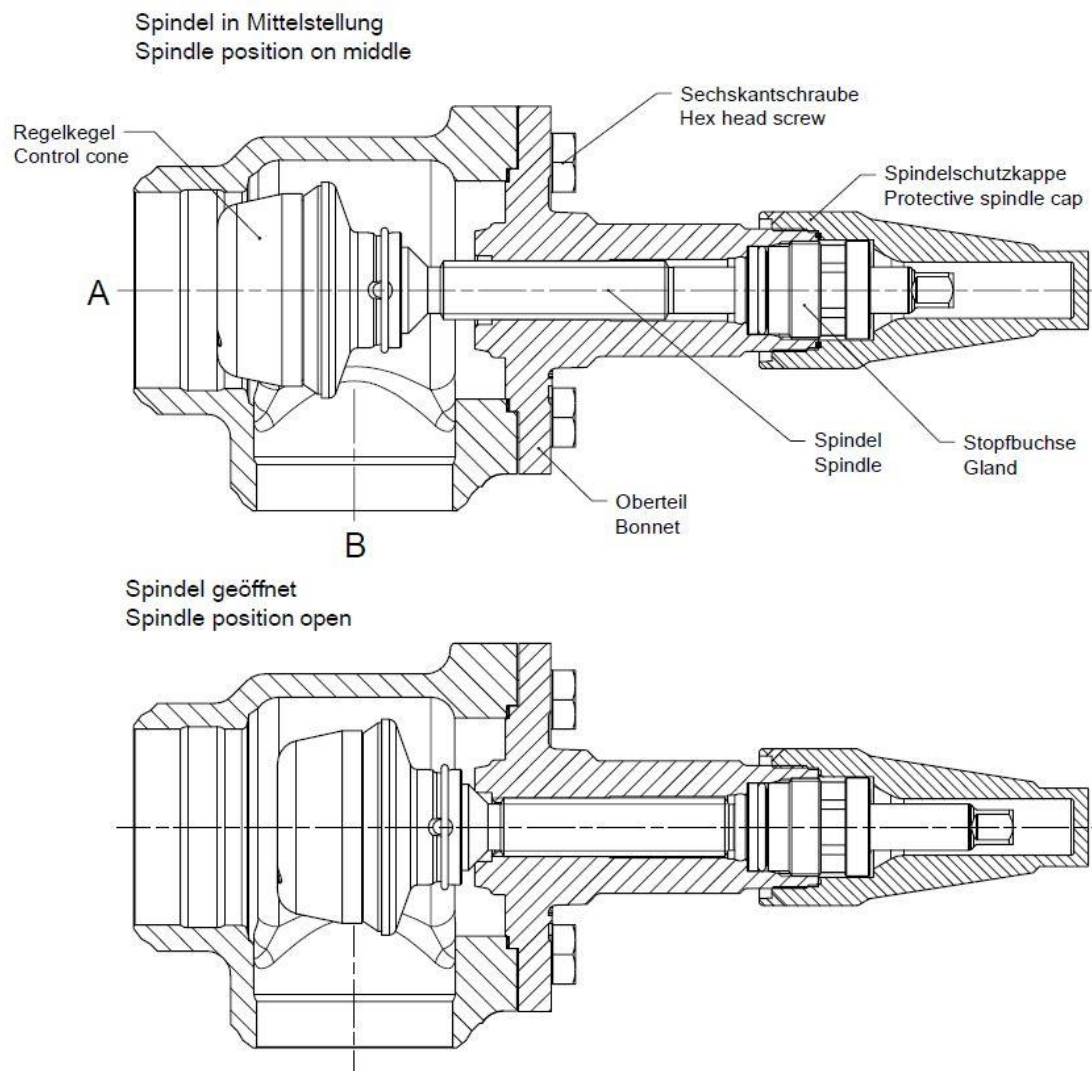



## Product description

The valve is an manual angle valve with additional regulating function designed for installation in refrigeration or air conditioning systems.

The valve is in compliance with EN 12284, the Pressure Equipment Directive 2014/68/EU and the Pressure Equipment (Safety) Regulation 2016, UK Statutory Instrument 2016 No. 1105.

## Identification

The valve is marked in accordance with EN 12284 by name plate:

Armaturenwerk Altenburg GmbH		
Typ:	Control valve Serie880-1	 UK CA 1521
AWA-Part-Nr.:	88010x000	
Size:	WBxxx	
Material:	1.6220+QT	
Normal size:	DNxxx	R
Operating range:	PS -1...63 bar TS -40...150°C PS' -1...47 bar TS' -60...-40°C	
Fluids:	Refrigerants EN378-1 (2016) PED Fluid group 1 and 2	 0090 EN12284
Year of manufacture - Serial number:		2020-yyyy
Made in Germany		

## Technical parameters

### Allowable pressure / temperature / service fluids:

Maximum allowable pressure PS:	PS 63bar	PS'47bar
Allowable temperature TS:	TS -40 ... 150°C	TS' -60 ... 150°C
Permitted service fluids:	Refrigerant acc. to EN 378-1 (2016) PED fluid group 1 and 2	

### Regulating/opening characteristics:

according to EN 12284 (for diagrams see appendix of these instructions)

### Leakage test:

according to DIN 8964-3 (<4,1 g/a R-134a at 10bar)

### Strength test:

according to EN 12284 at 1.43fold PS (valve housing and bonnet checked separately)

### Cleanliness of interior:

according to DIN 8964-1

### Classification pursuant to Pressure Equipment Directive 2014/68/EU and PE(S)R 2016:

valve DN25 Article 4 (3) respectively Part 1 Regulation 8  
valve DN32 to DN100 Category II

### Note on the permissible pressure difference for opening and closing:

According to EN 12284, the permissible pressure difference for opening and closing is limited according the following table:

Valve size	DN100
Flow direction A to B permissible pressure difference for opening and closing	44bar



## Design features

- The material of the valve components and the manufacturing method are selected in conformity with the EN 12284, the Pressure Equipment Directive 2014/68/EU, the Pressure Equipment (Safety) Regulation 2016 and the RoHS Directive 2011/65/EU thus guaranteeing the reliability for the operating range indicated.
- The valve housing and bonnet material of cast steel (G20Mn5+QT) provides for both a high degree of media compatibility and corrosion resistance.
- The valve is a shut-off valve and is equipped with an additional regulating function, this is achieved by a special contour of the valve cone. The direction of flow is from A to B (see functional principle).
- The set spindle or valve cone position can be secured with a clamping ring.
- The valve cone with soft-material seal is mounted to the spindle in a rotatable and vibration-protected manner.
- The valve spindle is designed with a square for actuation and has a metal back sealing function, this is only effective when the valve is fully open.
- The stuffing box is equipped with a spring-loaded seal, a guide ring and a scraper ring. This combination ensures maximum tightness and operational reliability over the specified range of application.
- The valve is supplied as standard with a pressure-tight stem protection cap with pressure relief device.
- The Series880-1 valve is compatible with the Series880 housings. A subsequent change of the functional unit (Shut-off valve Series880, Strainer Series884, Check valve Series885 or lockable check valve series886) is possible in the respective nominal width.
- Types of connection:

**Connection "2x WB"** – Butt weld connection according to EN 12627 to weld on pipes according to EN 10220 for DN25 to DN100 as well as corresponding inch dimensions.

Example: Shut-off valve cast Series880-1 - 2x WB88,9

Valve size	DN25	DN32	DN40	DN50	DN65	DN80	DN100
Pipe diameter [mm]	33,7	42,4	48,3	60,3	76,1	88,9	114,3
Wall thickness [mm]	2,6	2,9	2,9	4,0	4,0	4,5	4,5

- When supplied the valve is painted. This coating provides corrosion protection until installation provided handling and storage takes place in dry condition.
- The service-friendly design makes it possible to purchase spare parts (packing gland, valve cone, spindle, gaskets, protective spindle cap) separately.

## Transport and Storage

Transport the valve by closed means of transport in the original packing protected against weather influences and store it in dry rooms.

## Mounting

### Principles

- The valve shall be arranged in the system so that it can be properly installed, operated and maintained. Depending on the weight, installation aids must be provided.

Valve size	DN25 – DN50	DN65	DN80	DN100
Valve complete [kg]	< 5	7	12	23
Bonnet [kg]	< 3	4	6	9

	<p><b>DANGER!</b>          Damage to valve possible.          Serious injuries and system failure during operation possible.          Valve to be installed without additional loads (forces, vibrations etc.).          Never use the valve as fixing points of pipes.</p>
---	---

- The dismounting space for mounting, spindle actuation or maintenance of the bonnet must be provided according to the table.
 

Nominal size	Removal space
everyone	> 250mm
- It must be possible to apply the necessary torques to operate the spindle (opening, regulating and closing) in a safe manner. A bypass line may be required to compensate for a high differential pressure for valves from size DN100.
- The flow may only pass the valve in one direction. The prescribed flow direction is the flow onto the valve cone (flow direction from A to B).
- The regulating/opening characteristics of the valves are shown in the appendix to these operating instructions.
- The clamping ring screw must be loosened before adjusting the spindle position. After the adjustment has been made, the clamping ring must be pushed flush against the stuffing box and then tightened with the clamping ring screw with a tightening torque of approx. 2Nm.
- The valve should be installed with the valve spindle in a horizontal position or with the valve spindle vertical upwards.
- The valve must be integrated into the pipe on both sides. An outlet side open to the outside is not permitted!
- Only authorized personnel shall be allowed to mount the valve.

	<p><b>DANGER!</b>          Any non-observance of these instructions may cause the valve/system to fail.          Most serious injuries and death possible.          Mounting and operation by personnel trained in refrigeration systems only.</p>
---	--

- No modifications of the valve permitted. If modifications become necessary, they have to be agreed with the manufacturer in writing prior to mounting.

	<p><b>WARNING!</b>          Product features may change.          Avoidable serious to very serious injuries or death possible.          Any modification of the valve has to be agreed with manufacturer in advance.</p>
---	---

## Mounting preparation

- When supplied the valve comes with additional protective means for transport. To avoid corrosion inside the valve and contamination, such protective means should be removed shortly before mounting.

**ATTENTION!**

Damage to interior components possible.  
Malfunction due to oxidation/contamination of interior components.  
Wait to remove the transport protection until shortly before mounting.

- The valve housing must be dismantled when welded into the pipe. The other components have to be stored in such a way that they protected against damage until use.

## Connecting the pipe

- The pipe must be of a dimension that fits the valve. If not, use adapters.
- Prepare the system connections so (bare metal and free from grease) that a high-quality joint can be achieved. Make sure there is no mechanical restraint.
- The welding procedure and the filler metal must be suitable for the material of the valve housing (G20Mn5+QT [material number: 1.6220+QT]) and the material of the pipe. Then, slowly cool down the system connection in the air.

**WARNING!**

Damage to valve (e.g. cracking) due to rapid cooling possible.  
Serious injuries and system failure during operation possible.  
Allow joint to cool down in the air.

- Clean the pipe connections made and interior of valve. Welding residues may cause long-term damage due to corrosion or malfunctions.

**CAUTION!**

Risk of increased corrosion and component damage.  
Serious injuries and system failure during operation possible.  
Properly clean the joint after joining.

## Assembling valve components

For assembly of valve proceed in the following order:

1. Check that the bonnet is complete and undamaged. The spindle must be brought into the middle position.
2. Clean the sealing surfaces of the valve cartridge and the bonnet. Then, place the gasket into the valve housing.
3. Carefully insert the bonnet into the housing.
4. Make the screw connection between the bonnet and the valve housing. Initially screw the screws hand-tight into the valve housing. Then, tighten the screws crosswise in min. 2 steps until the nominal size-dependent torque has been reached.



### ATTENTION!

Check components for damage and pollution prior to assembly.  
 Malfunction due to component damage.  
 Replace damaged components using original spare parts.

The following torques apply to the valve assembly (Nm):

Valve size	Screws bonnet	Spindle square	Spindle closed	Spindle opened	Packing gland	Protective spindle cap
DN 25	30 +5	□9,5mm	50 +10	55 +10	50 +10	60 +10
DN 32	30 +5	□9,5mm	50 +10	55 +10	50 +10	60 +10
DN 40	50 +10	□12,7mm	50 +10	60 +10	50 +10	60 +10
DN 50	50 +10	□12,7mm	50 +10	60 +10	50 +10	60 +10
DN 65	120 +20	□12,7mm	60 +10	60 +10	50 +10	60 +10
DN 80	140 +20	□14mm	80 +10	110 +10	100 +10	80 +10
DN100	140 +20	□14mm	100 +10	110 +10	100 +10	80 +10



### WARNING!

Any excessive torques or non-observance of the mounting sequence may cause failures.  
 Serious injuries and system failure during operation possible.  
 Observe the torques.

## Commissioning

### Principles

- The valve housing and the bonnet have already been tested for leakage and strength by the manufacturer.
- The valve and the system into which it is installed, may only be commissioned if they have been checked, with due regard to the intended mode of operation, for proper condition as to assembly, installation, set-up conditions and safe functioning.
- After mounting and initial start-up according to EN 378-2:2016 by check again for leakage and strength and effective corrosion protection.

## Steps of commissioning

1. Check the system for leakage and pressure resistance by suitable means (e.g. helium, dry nitrogen).



### **DANGER!**

Risk of valve bursting.  
Most serious injuries possible.  
The test pressure must not exceed the maximum allowable pressure (PS).  
Strictly observe the safety information (e.g. EN 378).

2. It is indispensable to apply an anticorrosive coating that meets the operating conditions. Make sure that the fabrication data remain legible.



### **CAUTION!**

Delayed failures due to corrosion possible.  
Serious injuries and system failure during operation possible.  
Apply a suitable anticorrosive coating.



### **ATTENTION!**

Loss of product conformity due to loss of name plate/markings.  
Loss of warranty.  
Marking must be legible.

3. Evacuating and filling the system with refrigerant.



### **DANGER!**

Risk of bursting if operated beyond the technical parameters.  
Most serious injuries possible.  
Observe the technical parameters of the valve.  
Avoid excessive filling of the system with refrigerant.

4. Setting the desired spindle position

- Before changing the spindle position, loosen the clamping ring screw.  
The packing gland must not be released before a spindle actuation.
- Depending on the flow rate value to be set, the spindle must be brought into the appropriate position and secured with the clamping ring against unintentional change of position.  
To do this, push the supplied clamping ring on the spindle flush against the stuffing box and then fix it with the clamping ring screw (tightening torque of approx. 2Nm).
- Then tighten the spindle protection cap with the specified tightening torque (see chapter "Assembly").



### **WARNING!**

Exceeding the tightening torques or non-compliance with the installation instructions can lead to damage.  
Serious injuries and system failure during operation possible.  
Use spindle lock and observe the torques.

5. Upon initial commissioning check the pipes for any abnormal vibration and record the operating data.



### **CAUTION!**

Cracks of the piping and the valve due to dynamic loads possible.  
Injuries and system failure during operation possible.  
Avoid heavy vibrations. Take safety measures if need be.

## Operation, Maintenance and Repair

### Principles

- The valve is maintenance-free.
- As part of the regular system inspection it should be checked for corrosion/damage/tightness and operability and its proper condition restored if necessary.



#### **WARNING!**

Media contact possible, contact with hot/cold surfaces.  
Burns, frostbites.  
Wear personal protective equipment during maintenance and inspections as prescribed by national regulations.

- If the valve spindle is to be operated for system maintenance, carefully remove the protective spindle cap.



#### **WARNING!**

Protective spindle cap is pressure-tight and may be pressurized.  
Serious injuries possible.  
Slowly remove the cap. Allow any service fluid escape from inside the cap if necessary.

- If it is not possible to achieve a pressure compensation, firmly screw the protective spindle cap again and apply the prescribed torque. If so, there is a malfunction of the valve and it will be necessary to check or replace the packing gland (see chapter "Repairs").
- Then, arrange the spindle in the relevant position applying the necessary torque (see chapter "Assembling"). It is imperative to perform a leakage test. Put the protective spindle cap in place again after the work has been completed.



#### **DANGER!**

Risk of valve bursting.  
Most serious injuries possible.  
The test pressure must not exceed the maximum allowable pressure (PS).  
Strictly observe the safety regulations (e.g. EN 378).

### Repairs

- If a proper functioning of the valve is no longer guaranteed, switch the system off, drain the refrigerant from the system (or system section) in an eco-friendly manner and vent the system (or system section).



#### **DANGER!**

Refrigerant may escape.  
Leaking refrigerant may cause most serious injuries.  
For repairs the system must have the right temperature, free from refrigerant and sufficiently ventilated.

- The valve housing is beyond repair. A faulty valve housing must be removed from the system and replaced by a new one.
- For repairs (valve housing, packing gland, valve cone, spindle, gaskets, protective spindle cap, clamping ring) use no other than original spare parts. When removing/installing the bonnet from the valve, insert a new bonnet gasket.



#### **WARNING!**

Valve damage due to defective spare parts/mounting.  
Avoidable serious injuries and system failure possible.  
Use no other than original spare parts for repairs.

- Install/commission according these instructions. It is imperative to carry out another leakage and strength test. No warranty is accepted by AWA for tightness in case of repair.

## Dismantling and Disposal

### Principles

- To dismantle the valve, shut off the system, remove the refrigerant from the system (or system section) in an environmentally friendly manner and sufficiently vent the system (or system section).

	<b>DANGER!</b>
	Refrigerant may escape. Leaking refrigerant may cause most serious injuries. For repairs the system must have the right temperature, free from refrigerant and sufficiently ventilated.

	<b>WARNING!</b>
	Media contact possible, contact with hot/cold surfaces. Burns, frostbites. Wear personal protective equipment during maintenance and inspection as prescribed by national regulations.

- The valve and its components can be recycled:
 

Valve housing, valve cone, bonnet:	steel scrap
Spindle, packing gland:	stainless steel scrap
Protective spindle cap:	aluminium scrap
Dust caps:	plastics (PE)

## Appendix: Regulating/opening characteristics

- Valve Series880-1 DN25

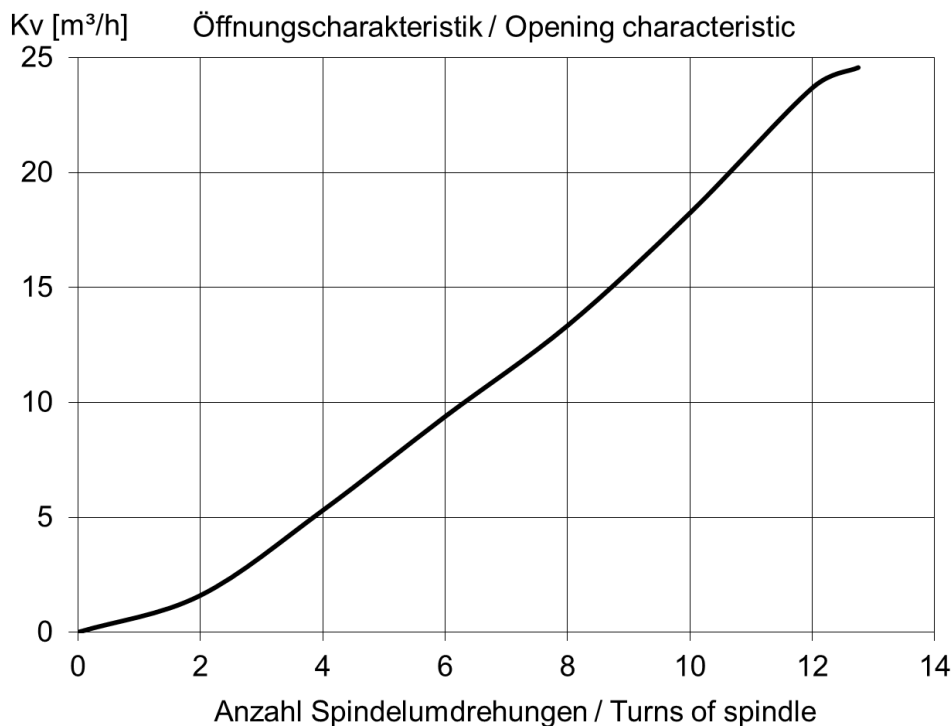

- Valve Series880-1 DN32

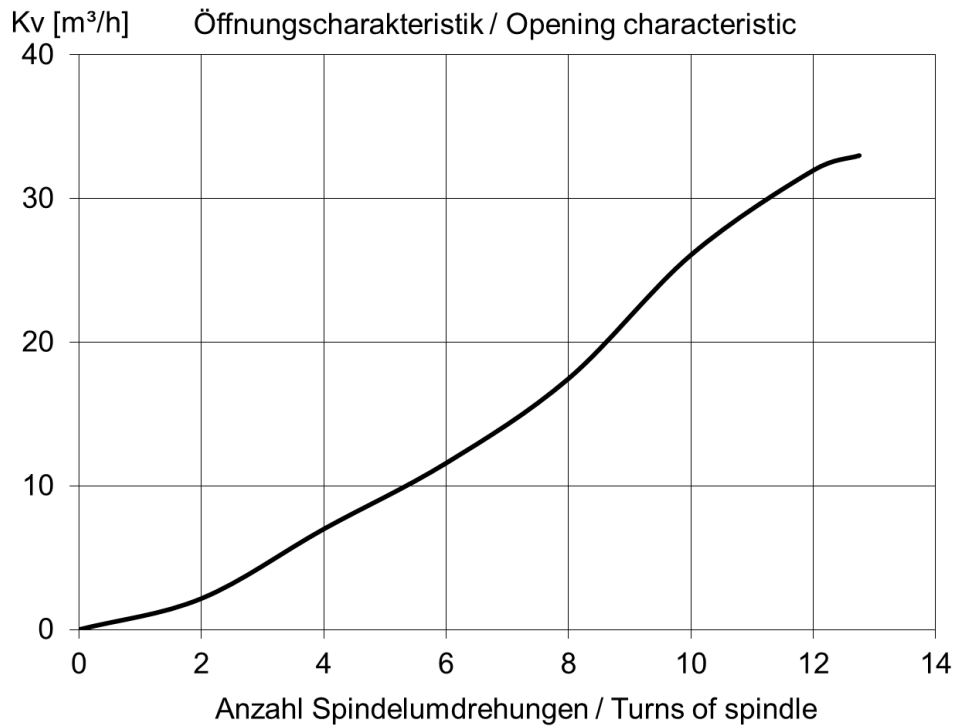

- Valve Series880-1 DN40

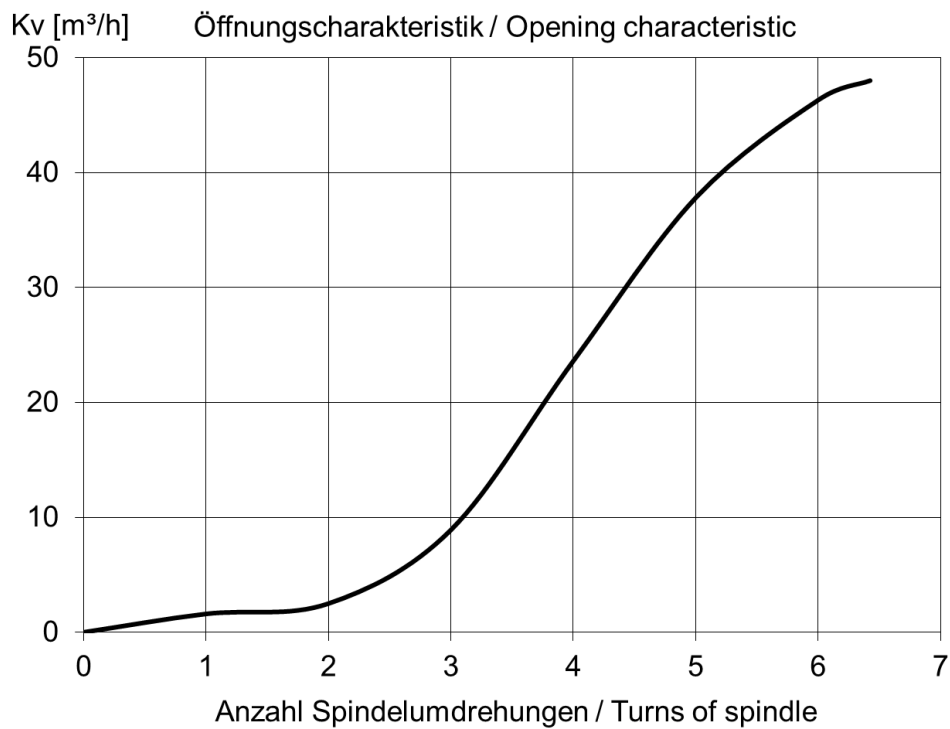



- Valve Series880-1 DN50

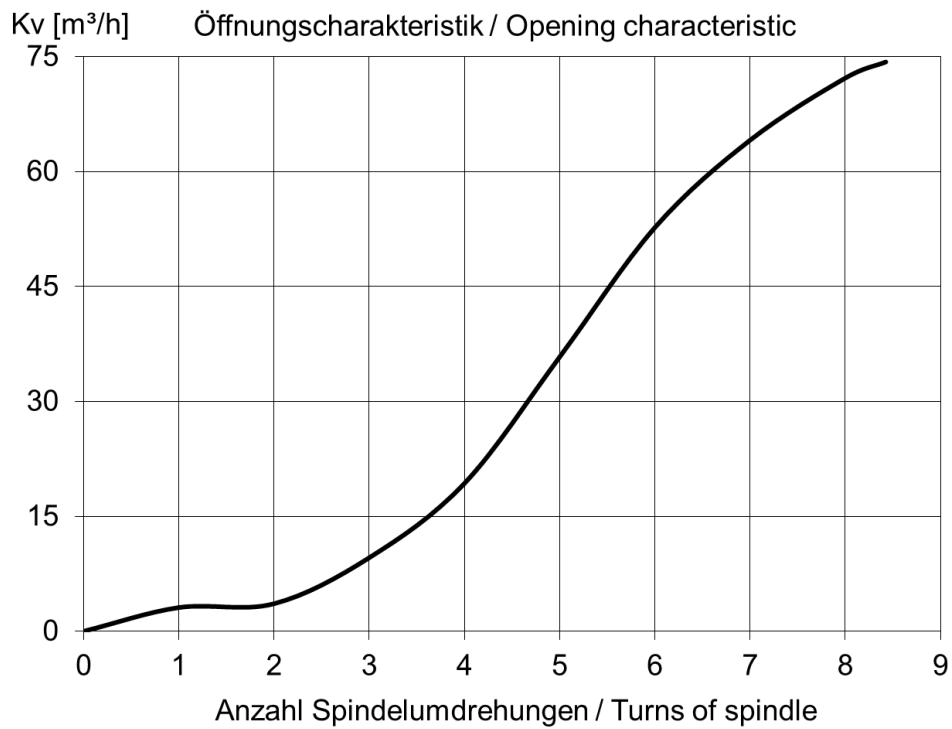

- Valve Series880-1 DN65

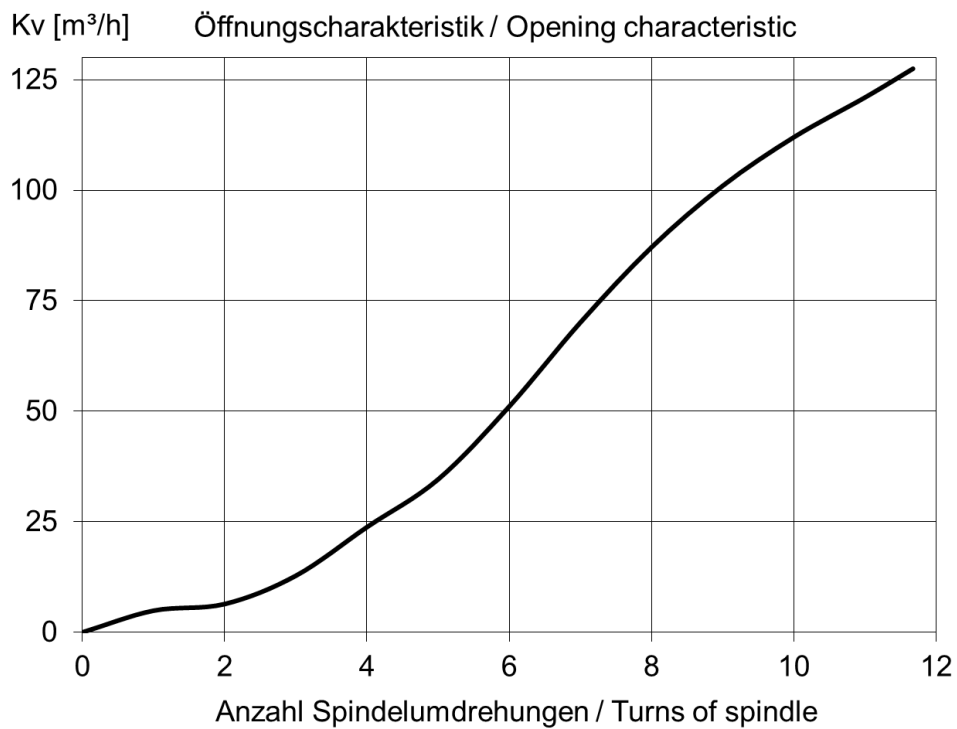

- Valve Series880-1 DN80

Kv [m<sup>3</sup>/h]      Öffnungscharakteristik / Opening characteristic

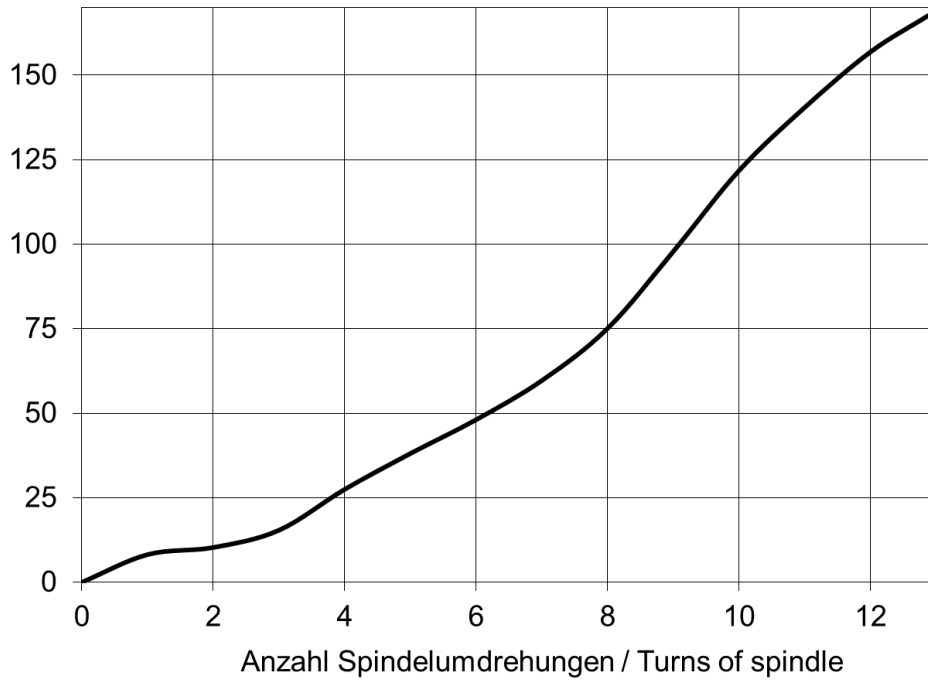

- Valve Series880-1 DN100

Kv [m<sup>3</sup>/h]      Öffnungscharakteristik / Opening characteristic

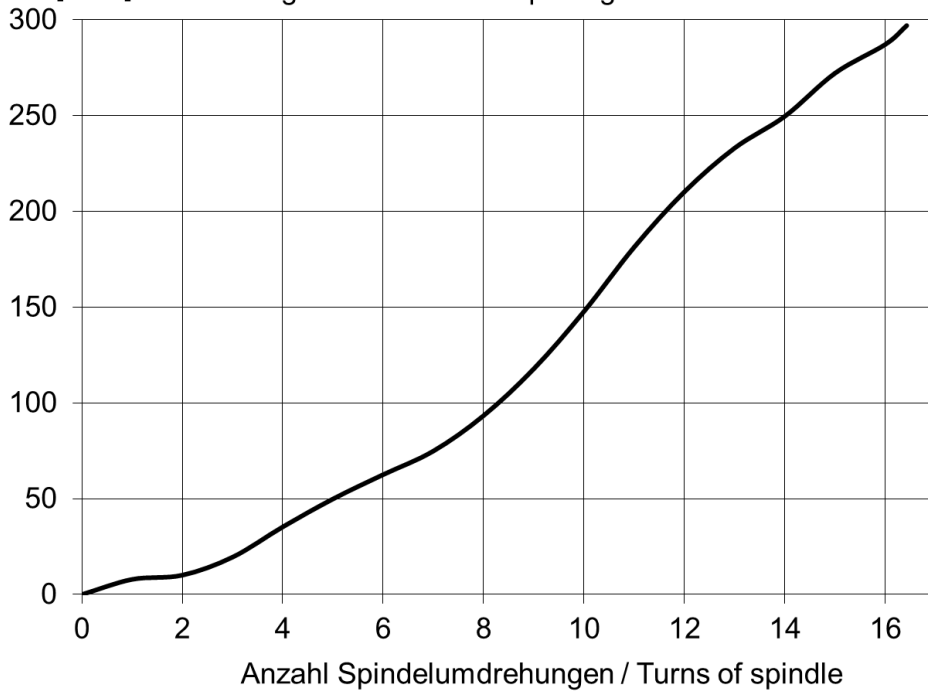





**Armaturenwerk Altenburg GmbH**  
Am Weißen Berg 30  
04600 Altenburg

Telephone +49 (0) 3447-893-0  
Telefax +49 (0) 3447-811-10

Internet: <http://www.awa-armaturenwerk.de>  
Email: [info@awa-armaturenwerk.de](mailto:info@awa-armaturenwerk.de)

Subject to change. As of: 10/2021  
Document 90000727 Revision 00