



Operating Instructions  
in compliance with  
Pressure Equipment Directive 2014/68/EU

FAS Manual Brass Shut-Off Valve DN10 through DN22



Please read these operating instructions carefully to ensure a safe operation and keep the same for further use.





## Contents

Safety.....	4
Authorized personnel.....	4
Residual dangers.....	4
Symbols used for safety information .....	4
General safety information .....	5
Other information .....	5
Description of valve .....	6
Types (possible combinations of connections).....	6
Operating principle .....	7
Product description .....	7
Identification .....	8
Technical parameters .....	8
Design features .....	9
Transport and Storage.....	9
Mounting.....	10
Principles .....	10
Mounting preparation.....	10
Connecting the pipe.....	11
Commissioning .....	12
Principles .....	12
Steps of commissioning.....	12
Operation, Maintenance and Repair .....	13
Principles .....	13
Repair .....	13
Dismantling and Disposal.....	14
Principles .....	14

## **Safety**

The FAS manual brass shut-off valve DN10 through DN22, hereinafter referred to as valve, is designed for use in refrigeration/air conditioning systems referred to as systems hereinafter. It may only be put into service if installed into the system unchanged in accordance with these instructions and as a whole is compliance with the statutory provisions.

The valve incorporates state-of-the-art technology and has been built according to the applicable regulations. Great valve has been set upon the user's safety.

These operating instructions are integral part of the contract and shall be kept throughout the entire life of the valve.

### **Authorized personnel**

Only trained and instructed personnel shall be allowed to do any work on the valve and system. As regards the qualification and expertise of the personnel the applicable rules and guidelines shall apply.





### **Residual dangers**

Unavoidable residual hazards may emanate from the valve. Every person working on this device shall therefore carefully read these instructions.

To be observed are for example:

- the generally accepted safety regulations,
- EC directives,
- Norms (e.g. EN 378) and all national provisions.







### **Symbols used for safety information**

	<p><b>DANGER!</b> Instructions on preventing imminent serious danger to persons. Imminent most serious injuries or death as a possible consequence. Any non-observance may lead to an immediate failure of the valve.</p>
	<p><b>WARNING!</b> Instructions on preventing potential serious danger to persons. Avoidable serious to very serious injuries or death as a possible consequence. Any non-observance can cause the valve to fail.</p>
	<p><b>CAUTION!</b> Instructions on preventing a minor danger to persons. Minor, reversible injuries cannot be excluded. Any non-observance may lead to a medium-term failure of the valve.</p>
	<p><b>ATTENTION!</b> Instructions on preventing potential damage to equipment. Minor, reversible injuries cannot be excluded. Any non-observance may lead to a medium-term failure of the valve.</p>

## General safety information

These operating instructions are based on the safety requirements of DIN EN 378-2 and DIN EN 12284.

Instructions to prevent hazards in all cycles of service life:

	<p><b>DANGER!</b> Risk of bursting if operated beyond the technical parameters. Most serious injuries and immediate system failure possible. Observe the technical parameters.</p>
	<p><b>WARNING!</b> Risk of bursting in an environment causing stress corrosion cracking. Most serious injuries and immediate system failure possible. Observe the environmental conditions for brass!</p>
	<p><b>WARNING!</b> Damage due to improper handling. Serious injuries and system failure possible. Never use the valve as transport, lifting or lashing point.</p>
	<p><b>WARNING!</b> Any non-observance of the instructions may cause the valve to fail. Avoidable serious to very serious injuries or death possible. Installation, operation and maintenance by authorized trained personnel only.</p>
	<p><b>WARNING!</b> Risk of service fluid to be released. Depending on the kind of service fluid serious to very serious injuries or death possible. Wear personal protective equipment (e.g. respirators, gloves).</p>
	<p><b>CAUTION!</b> Very cold or very hot surface temperatures possible. Frostbites/burns possible. Wear personal protective equipment (e.g. respirators, gloves).</p>

## Other information

The information contained herein represents to the best of our belief our knowledge at the time when these instructions were prepared. They shall give you guidance how to safely handle the valve during transport, storage, installation, commissioning, maintenance and dismantling/disposal. A final decision as to whether the valve suits the purpose is to be taken by the user. This information shall not be deemed a warranty of quality or a guarantee.

Any modification of the valve and operation under other than the prescribed parameters shall not be allowed and will result in the loss of the conformity declaration and all liability claims.

## Description of valve

### Types (possible combinations of connections)

straight-way valve

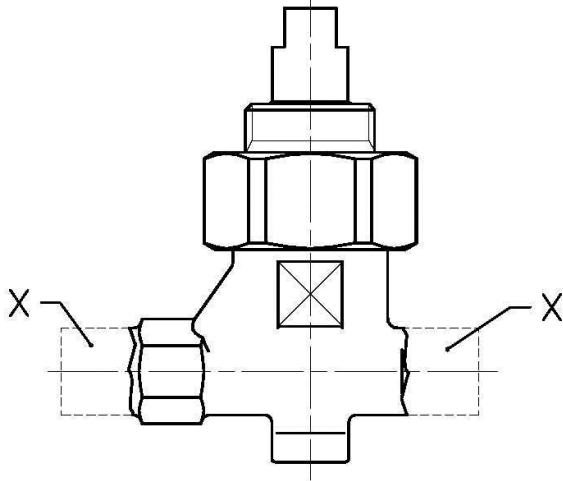

angle valve

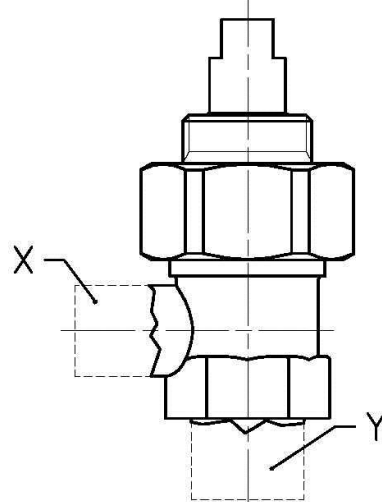

### Design featuring a

handwheel

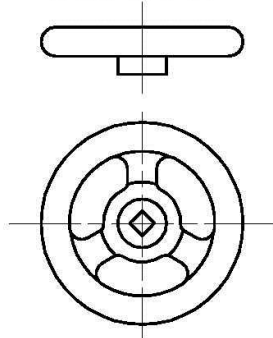

cap

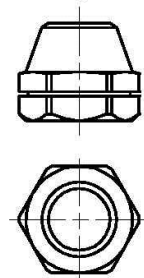

### connection for angle/straight-way valves

A  
flared coupling male  
for X; Y

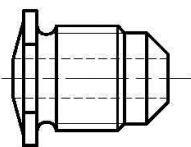

B  
NPTF for Y

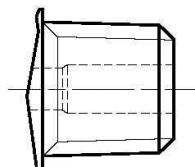

C  
brazed connection  
for X; Y

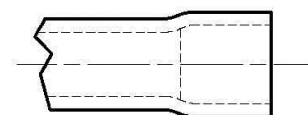

Installation dimensions can be gathered from the AWA product catalogue and technical documents respectively. The connecting options A through D are explained in more detail in "Design features".

## Operating principle

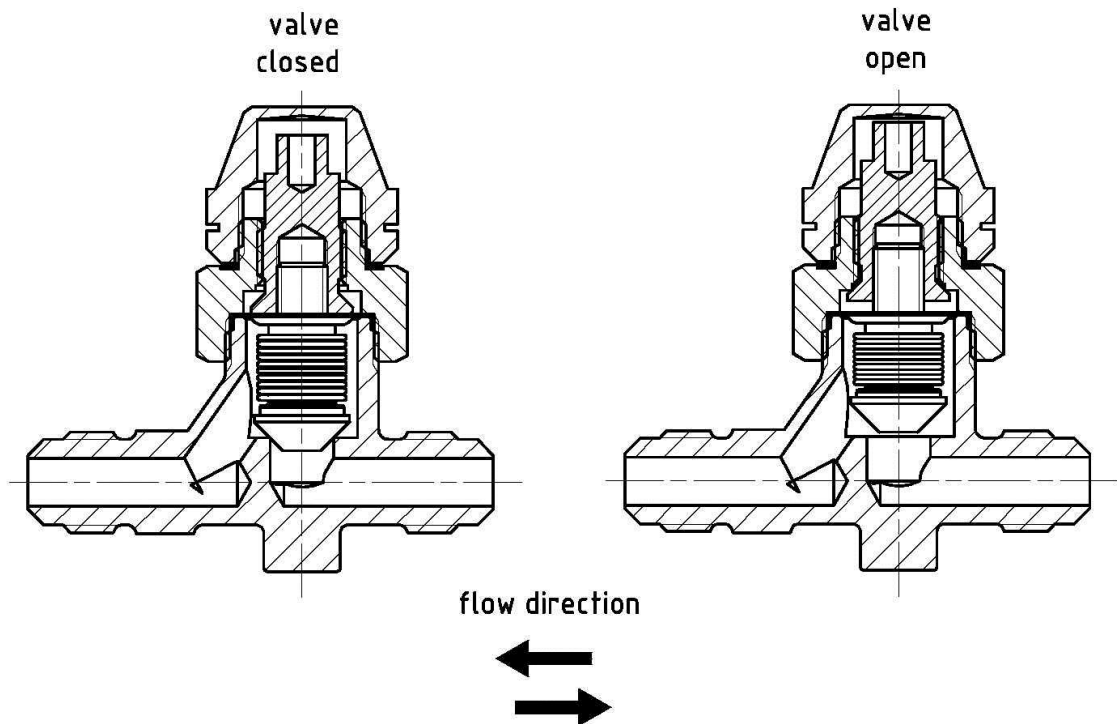

## Product description

The manual brass shut-off valve DN10 through DN22 is a stop valve for refrigeration or air conditioning systems and for operation it has to be fully open or fully closed. According to DIN EN 378-2 the valve can only be operated by use of a tool/handwheel/spindle wrench. The position of the valve spindle as supplied (normally open) can be gathered from the technical documentation. The protective spindle cap is finger-tight.

The mounting position and flow direction are optional.

The valve is in compliance with DIN EN 12284:2003 and Pressure Equipment Directive 2014/68/EU. The ROHS directive 2011/65/EC and REACH regulations No. 1907/2006/EC are complied with.



## Identification

The valve is marked in accordance with DIN EN 12284 on the valve body as follows:

- Manufacturer's logo
- Type designation
- Date of manufacture
- Permissible pressure in bar
- Nominal diameter
- Housing material

## Technical parameters

### **Pressure/Temperature allocation:**

Depending on the data given in the technical documentation.

### **Service fluids:**

Refrigerants according to DIN EN 378-1-2012, DGRL fluid group 2 and associated refrigerator oils according to DIN 51503-1.

On request other refrigerants can be permitted. It is explicitly indicated in the technical documentation.

### **Leakage test:**

according to DIN 8964-3 (<4.1 g/a R-134a at 10bar)

### **Strength test:**

according to DIN EN 12284 at 1.43-fold PS

### **Cleanliness of interior:**

according to DIN 8964-1

### **Classification pursuant to Pressure Equipment Directive (PED 2014/68/EU):**

As per Article 4 (3) of good engineering practice.





## Design features

- The material of the valve components and the manufacturing method are selected in conformity with the EN12284:2003 and Pressure Equipment Directive 2014/68/EU thus guaranteeing the reliability for the operating range indicated.
- The use of heat-resistant materials and connecting elements obviates the need of dismantling the valve when the system is installed (brazing).
- The valve spindle comes with wrench flats for operation and has a back seat function. The back seat is only effective when the valve is fully open. Sealing between the spindle and the housing is by corrugated pipe.
- The valve comes with a highly leak-proof protective spindle cap of brass as a standard feature. A handwheel type is available on request. Usually cap valves cannot be converted to hand-wheel valves.
- Types of connection

**Connection "A"** – Detachable 90° flared coupling with male connection to render a joint with copper pipes (outside diameter 10 to 22mm or 3/8" to 7/8") and cap nut.

Size	Thread	Copper pipe inches / metric	
SAE 3/8"	5/8" - 18 UNF	3/8"	10
SAE 1/2"	3/4" - 16 UNF	1/2"	12
SAE 5/8"	7/8" - 14 UNF	5/8"	16
SAE 3/4"	1 1/16" - 12 UNF	3/4"	18
SAE 7/8"	1 1/4" - 12 UNF	7/8"	22

**Connection "B"** – Detachable threaded connection according to DIN 3866 with NPTF threaded journal acc. to ANSI/ ASME B 1.20.1 and ANSI B1.20.3.

**Connection "C"** – Brazed capillary connection to render a brazed joint with copper pipes acc. to DIN EN 12735-1:2010 for outside diameters 10 to 22 mm or inch-type pipes 3/8" to 7/8".

- If transported and stored in dry condition, corrosion protection is ensured until installation.
- The service-friendly design makes it possible to purchase spare parts separately (e.g. valve bonnet, spare cone, gaskets, protective spindle cap, etc.) incl. mounting instructions.

## Transport and Storage

Transport the valve by closed means of transport in the original packing protected against weather influences and store it in dry rooms.

## Mounting

### Principles

The valve shall be arranged in the system so that it can be properly operated and maintained.

	<p><b>DANGER!</b>            Damage of valve possible.            Serious injuries and system failure possible during operation.            Valve to be installed without additional loads (forces, vibrations, etc.).            Never use the valve as fixing point of pipes.</p>
---	---

- In particular a removal space of min. 100mm shall be provided for spindle operation, the protective spindle cap and the replacement of the valve bonnet.
- A safe operation of the spindle (opening and shutting off) at the required torques must be possible.
- Only authorized personnel shall be allowed to mount the valve.

	<p><b>DANGER!</b>            Any non-observance of these instructions may cause the valve/system to fail.            Most serious injuries and death possible.            Mounting and operation by personnel trained in refrigeration systems only.</p>
---	--

- No modifications of the valve permitted. If modifications become necessary, they have to be agreed with the manufacturer prior to mounting.

	<p><b>WARNING!</b>            Product features may change.            Avoidable serious to very serious injuries or death possible.            Any modification of the valve has to be agreed with manufacturer in advance.</p>
---	---

### Mounting preparation

- When supplied the valve is open and may come with additional protective means for transport. To avoid corrosion inside the valve and contamination, such protective means should be removed shortly before mounting.

	<p><b>ATTENTION!</b>            Possible damage of interior components.            Malfunction due to oxidation/contamination of internal components.            Remove the transport protection shortly before mounting.</p>
---	---

- Connections "C" only: Arrange the spindle centrally. For correct brazing the valve bonnet needs not be removed.

	<p><b>ATTENTION!</b>            Damage of internal components possible.            Malfunction of valve due to thermal overload.            Centrally arrange the spindle for thermal joining processes.</p>
---	--

## Connecting the pipe

1. The pipe / connection must be of a dimension that fits the valve. If not, use adapters.
2. Connections A and B only: Screw the valve with the mating part free of any mechanical constraint. Use the wrench flats at the valve body for counter pressure. Observe the torques (item 6).



### WARNING!

Excessive torques or non-observance of the mounting order may result in failures.  
Serious injuries and system failure during operation possible.  
Observe the torques!

3. Prepare the system connections so (bare metal and free from grease) to achieve a high-quality joint.

While brazing scavenge the relevant pipe sections with shielding gas. A cooling of the valve body with connection variant C is recommended. Then, cool down the system connection in the air.

Clean the pipe connections rendered. Flux material residues are very corrosive and may cause long-term damage.



### WARNING!

Damage of valve due to strong heating possible.  
Serious injuries and system failure possible during operation.  
Do not heat the system connection above 700°C.  
Keep the flame away from the valve.



### WARNING!

Damage of valve (e.g. cracks) due to rapid cooling possible.  
Serious injuries and system failure during operation possible.  
Allow the joint to cool down in the air.



### ATTENTION!

Damage of internal components possible.  
Malfunction due to oxidation of internal components.  
Scavenge with shielding gas while doing the joining.



### CAUTION!

Risk of increased corrosion and component damage.  
Serious injuries and system failure possible during operation.  
Properly clean the joint after joining.

4. Depending on which condition is intended fully open or close the spindle. Then, tightly screw on the protective spindle cap at the tightening torque defined. If a subassembly is to be mounted, shut the pipe ends using dust caps until further use.
5. Observe the following torques for nominal sizes DN 10 to 22 (Nm):

Nominal dia.	Spindle closed	Spindle open	Protective spindle cap	Valve cap	Flared coupling
DN 10	10 + 2	10 + 5	30 + 5	80 + 10	33 + 9
DN 12	10 + 2	10 + 5	30 + 5	80 + 10	50 + 12
DN 15	10 + 5	12 + 5	30 + 5	110 + 10	63 + 14
DN 16	10 + 5	12 + 5	30 + 5	110 + 10	63 + 14
DN 18	15 + 3	15 + 5	30 + 5	140 + 10	90 + 20
DN 22	15 + 3	15 + 5	30 + 5	140 + 10	110 + 20

## Commissioning

### Principles

- The valve has already been tested for leakage and strength by the manufacturer.
- The valve and the system into which it is installed, may only be commissioned if they have been checked, with due regard to the intended mode of operation, for proper condition as to assembly, installation, set-up conditions and safe functioning.
- After mounting and initial start-up according to DIN EN 378-2:2012 check again for leakage and strength and an effective corrosion protection.

### Steps of commissioning

1. Check the system for resistance to pressure by suitable means (e.g. helium, dry nitrogen).

	<p><b>DANGER!</b>            Danger of bursting.            Most serious injuries possible.            The test pressure must not exceed the maximum allowable pressure (PS).            Strictly observe the safety information (e.g. DIN EN 378).</p>
---	---

2. Evacuating and filling the system with refrigerant.

	<p><b>DANGER!</b>            Danger of bursting if operated beyond the technical parameters.            Most serious injuries possible.            Observe the technical parameters of the valve.            Make sure the system is not filled with an excessive amount of refrigerant.</p>
---	--

3. Depending on the intended operating condition either completely open or close the spindle. Then, put on the protective cap and tighten it applying the prescribed torque (see chapter "Mounting").

	<p><b>WARNING!</b>            Any torque beyond the limits may lead to failure.            Serious injuries and system failure during operation possible.            Observe the torques.</p>
---	---

4. Upon initial commissioning check the pipes for any abnormal vibration and record the operating data.

	<p><b>CAUTION!</b>            Cracks of the piping and the valve due to dynamic loads possible.            Injuries and system failure during operation possible.            Avoid heavy vibrations. Take safety measures if need be.</p>
---	---

## Operation, Maintenance and Repair

### Principles

- The valve is maintenance-free.
- As part of the regular system inspection it should be checked for corrosion/damage and operability and its proper condition restored if necessary.



**WARNING!**

Media contact possible, contact with hot/cold surfaces.

Burns, frostbites

Wear personal protective equipment as prescribed by national regulations during maintenance and inspections.

- If the valve spindle has to be operated for system maintenance, carefully remove the protective spindle cap. If no pressure compensation can be effected, put the protective spindle cap in place again and tighten it. If so, it indicates a malfunction of the valve and the system has to be stopped without delay.



**WARNING!**

The protective spindle cap is pressure-proof and may be pressurized.

Serious injuries possible.

Slowly remove the protective cap of the spindle. Allow any service fluid escape from inside the cap if necessary.

Then, put the spindle in the correct position applying the necessary torques (see chapter Mounting). Upon completion of work put the protective spindle cap in place again.

### Repair

- If the valve needs repair, shut down the system, drain the refrigerant from the system (or system section) in an environmentally friendly manner and ventilate the system.



**DANGER!**

Refrigerant may escape.

Leaking refrigerant may cause most serious injuries.

For repairs the system must have the right temperature, free from refrigerant and sufficiently ventilated.

- For repairs use no other than original spare parts. For mounting/start-up follow these operating instructions. It is indispensable to do a leakage and strength test once again. AWA assumes no warranty for tightness after repairs.



**WARNING!**

Valve damage due to defective spare parts/mounting.

Avoidable serious injuries and system failure possible.

Use no other than original spare parts for repairs.

## Dismantling and Disposal

### Principles

- To dismantle the valve, shut off the system, remove the refrigerant from the system (or system section) in an environmentally friendly manner and sufficiently ventilate the system (or system section).

	<b>DANGER!</b>
	<p>Possible escape of refrigerant. Escaping refrigerant may cause most serious injuries. For repairs the system must have the right temperature, free from refrigerant and sufficiently ventilated!</p>

	<b>WARNING!</b>
	<p>Media contact possible, contact with hot/cold surfaces. Burns, frostbites Wear personal protective equipment as prescribed by national regulations during maintenance and inspections.</p>

- The valve and its components can be recycled.

Valve body:	brass scrap
Internal parts of valve:	brass scrap
Protective spindle cap:	brass scrap
Dust caps:	plastics (PE)





**Armaturenwerk Altenburg GmbH**

Am Weißen Berg 30  
04600 Altenburg

Telefon +49 (0) 3447-893-0  
Telefax +49 (0) 3447-811-10

Internet: <http://www.awa-armaturenwerk.de>  
E-Mail: [info@awa-armaturenwerk.de](mailto:info@awa-armaturenwerk.de)

Subject to change of: 09.2016  
Document 9000704 Revision 01