

Schraderventile - "Schrader"-Valves

T-Varianten von Schraderventilen - T-Variante of "Schrader"-Valves

Lieferprogramm mit Verschlusskappe (incl. Dichtung) und Ventileinsatz

Delivery program with cover cap and valve core

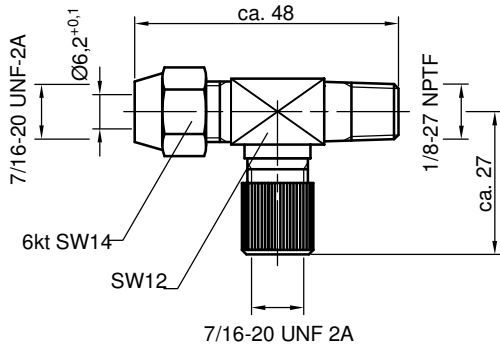

Order Number	590 043 000
--------------	-------------

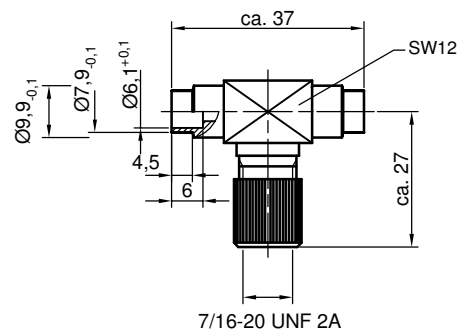

Order Number	590 140 000
--------------	-------------

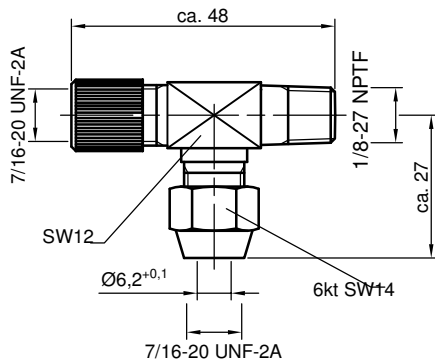

Order Number	590 042 000
--------------	-------------

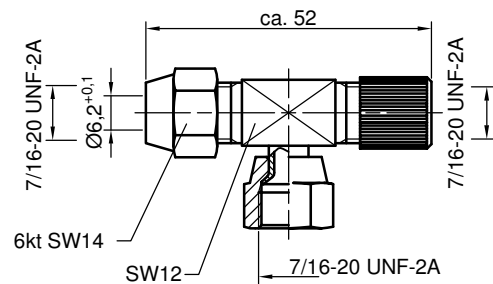

Order Number	590 145 000
--------------	-------------

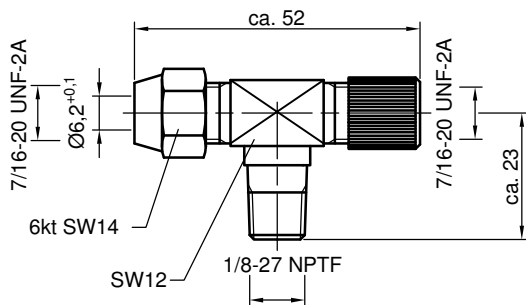

Order Number	590 041 000
--------------	-------------

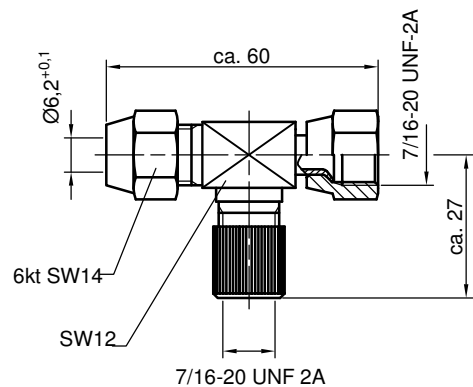

Order Number	590 146 000
--------------	-------------

Werkstoff: Messing

Kennwerte:
 T_s: - 40 °C ... + 100 °C
 P_s: 28 bar
 Medium: Kältemittel nach EN 378-1
 L1, R134a

Material: brass

Parameters:
 T_s: - 40 °C ... + 100 °C
 P_s: 28 bar
 Medium: refrigeration medium EN 378-1
 L1, R134a