

Eckventil mit Rotalock- und Bördelanschluss Angle Valve with rotalock- and flare connection

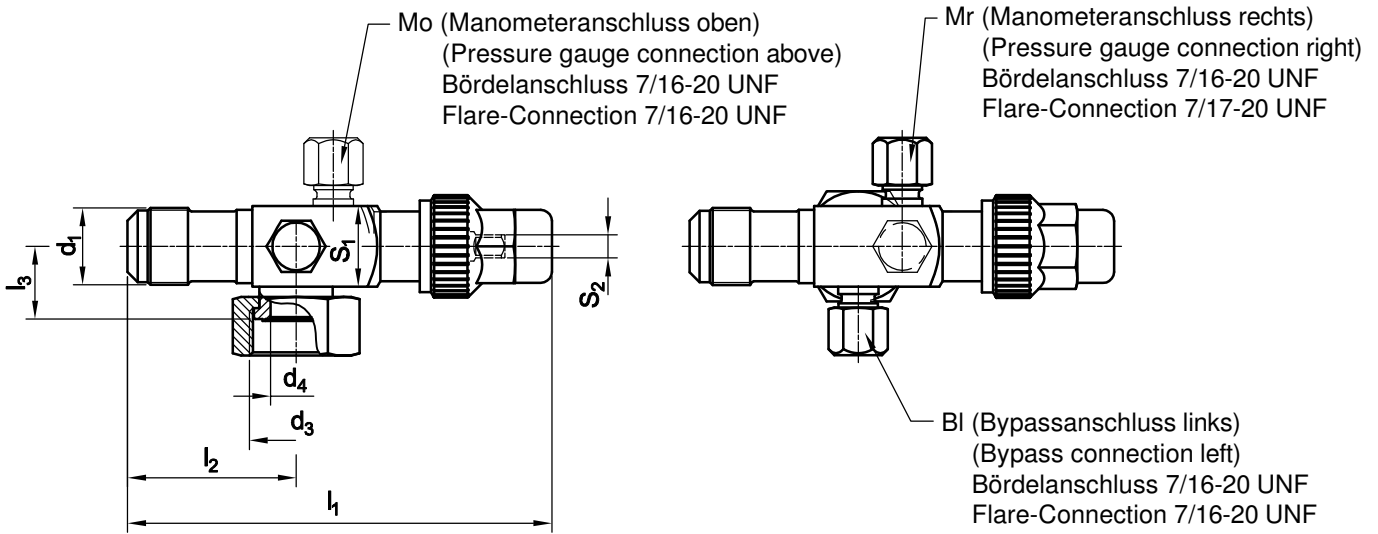

Korrosionsschutz Cu/Sn Corrosion protection Cu/Sn

Order Number Mr / BI
500 270 050
500 272 050
500 273 050
500 670 050
500 672 050
500 673 050
503 270 050
503 271 050
503 670 050
503 671 050

Order Number Mo
500 210 050
500 212 050
500 213 050
500 610 050
500 612 050
500 613 050
503 210 050
503 211 050
503 610 050
503 611 050

d ₁	d ₃	d ₄	~l ₁	l ₂	l ₃	S ₁ 4kt	S ₂ 4kt	Kv m ³ /h		
7/16-20 UNF	3/4-16 UNF	9,5	88,5	27	19	19	6,35	0,85		
5/8-18 UNF		9,5	90,5	29	19			1,6		
3/4-16 UNF		9,5	91	29,5	19			2,35		
7/16-20 UNF	1-14 UNS	9,5	88,5	27	19			22	4,0	
5/8-18 UNF		9,5	98,5	29	19					0,85
3/4-16 UNF		9,5	101,5	38	19					1,6
7/8-14 UNF	1 1/4-12 UNF	14	106,5	39,5	20	22	6,35	4,0		
1 1/16-14 UNS		14		46	20					
7/8-14 UNF		14		39,5	21,5					
1 1/16-14 UNS		14		46	21,5					

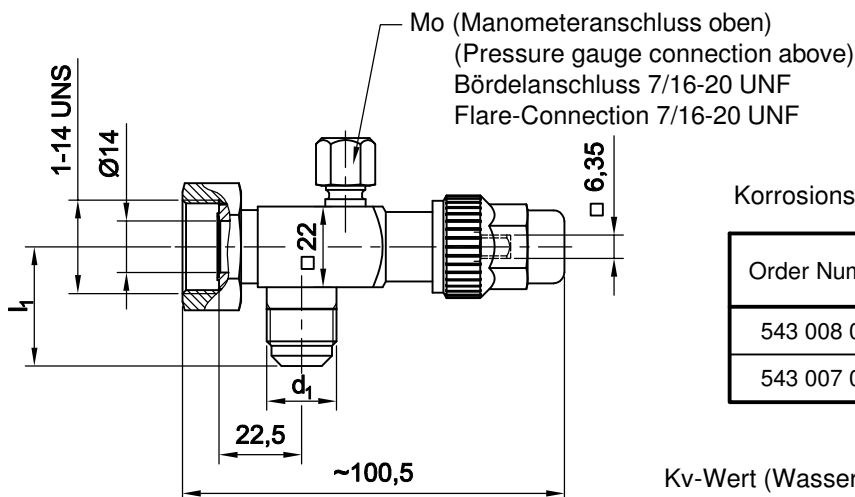

Korrosionsschutz Cu/Sn Corrosion protection Cu/Sn

Order Number	d ₁	l ₁	Kv m ³ /h
543 008 050	7/8-14 UNF	39	4,0
543 007 050	3/4-16 UNF	32,5	

Kv-Wert (Wasserdurchfluss bei einer Druckdifferenz von 1 bar)
 Kv-value (water flow with a difference of pressure of 1 bar)