

## Löt nipple - Soldering nipple

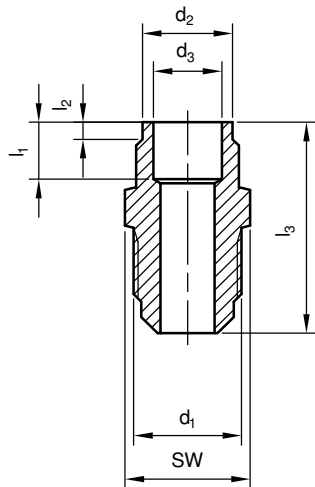

Order Number	FAS Typ	d <sub>1</sub>	d <sub>2</sub>	d <sub>3</sub>	l <sub>1</sub>	l <sub>2</sub>	l <sub>3</sub>	SW
871 101 000	HLN6	7/16-20 UNF	9,9	6	6	3	28	12
871 102 000	HLN10	5/8-18 UNF	13,8	10	9	3	33	17
871 103 000	HLN12	3/4-16 UNF	15,8	12	10	3	37	19
871 104 000	HLN15	7/8-14 UNF	19,8	15	12	3,5	39	22
871 105 000	HLN16	7/8-14 UNF	19,8	16	12	3,5	39	24
871 106 000	HLN18	1 1/16-14 UNS	24,8	48	14	4	46	27
871 107 000	HLN22	1 1/4-12 UNF	29,8	22	17	4	53	32

Material: CuZn39Pb3 (gefertigt aus Stangenmaterial)  
 (made by rod material)

## Schweißnippel - Welding nipple

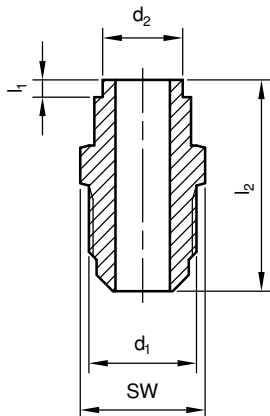

Order Number	FAS Typ	d <sub>1</sub>	d <sub>2</sub>	l <sub>1</sub>	l <sub>2</sub>	SW
871 201 000	SN6	7/16-20 UNF	8	3	28	14
871 202 000	SN10	5/8-18 UNF	12		33	17
871 203 000	SN12	3/4-16 UNF	14		37	19
871 204 000	SN15	7/8-14 UNF	18	3,5	39	22
871 206 000	SN18	1 1/16-14 UNS	21	4	46	19
871 208 000	SN22	1 1/4-12 UNF	28		53	19

Material: S235 JRG2 EN10277

## Schweißbuchse - Welding shaft insert

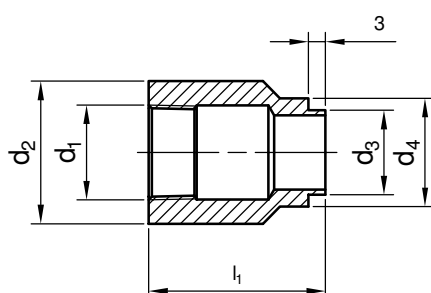

Order Number	FAS Typ	d <sub>1</sub>	d <sub>2</sub>	d <sub>3</sub>	d <sub>4</sub>	l <sub>1</sub>
871 901 000	SB1/8 NPT	1/8-27 NPTF	16	7,9	12	24
871 902 000	SB1/4 NPT	1/4-18 NPTF	20	9,9	15	28
871 903 000	SB3/8 NPT	3/8-18 NPTF	24	14,8	19	31
871 904 000	SB1/2 NPT	1/2-14 NPTF	28	18,8	23	32
871 905 000	SB3/4 NPT	3/4-14 NPTF	35	21,8	26	36
871 906 000	SB1 NPT	1-11,5 NPTF	45	26,8	34	43

Material: S235 JRG2 EN10277